

# TITAN

I N D U S T R I A L

P.O.Box 791, Travelers Rest, S.C. 29690  
Service\Parts (800) 845-4141



## OWNER'S MANUAL

### TG 6500ES Industrial Generator

The Emission Control System for this generator is warranted for standards set by the Environment Protection Agency.

#### **IMPORTANT!**

It is extremely important to read and understand the entire contents of this Owner's Manual for the TITAN Model TG 6500ES before attempting to operate the generator. This is a gas engine powered, industrial strength generating unit of electrical power. The gas engine and the generator are both potentially extremely hazardous and could cause physical injury or even death if improperly used.

#### **WARNING!**

**Do Not Operate Equipment until reading & understanding Owner's Manual!**  
**Disconnect all loads before starting or stopping generator.**  
**Allow to run for a few minutes with no load before stopping.**

Revision # 030321A

**IMPORTANT !**  
**READ FIRST**

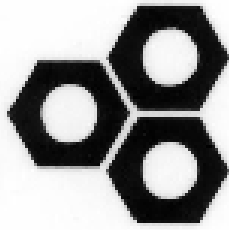

**TITAN**  
I N D U S T R I A L

**OWNER'S MANUAL**  
**MODEL TG 6500ES**  
**Industrial Generator**

**It is extremely important to read and understand the entire contents of this Owner's Manual for the TITAN Model TG 6500ES before attempting to operate the generator. This is a gas engine powered, industrial strength generating unit of electrical power. The gas engine and the generator are both potentially extremely hazardous and could cause physical injury or even death if improperly used.**

**TITAN shall not be responsible for any consequences resulting from improper use of this equipment. The operator is required to read the entire contents of this manual before attempting to operate the unit. If the operator does not completely understand the instructions and all of the hazards of operating this unit after reading this manual, he/she must call the factory at 1-800-845-4141 to answer these questions to his/her complete satisfaction before proceeding.**

**READ AND COMPLETELY UNDERSTAND** entire contents of this Owner's Manual and become familiar with the unit before attempting to start using this equipment! It is your responsibility to know its applications, limitations, and hazards! Call the factory at 1-800-845-4141 with any questions.

**FOR OUTDOOR USE ONLY!** Never use this unit inside any enclosure including the generator compartment of a recreation vehicle (RV) or inside any building. No modifications will eliminate the danger of possible carbon monoxide poisoning, fire, or explosion.

**TWO (2) FEET OF CLEARANCE** on all sides is required even while using outdoors.

**THIS UNIT IS SOLD SOLELY FOR THE PURPOSE OF PORTABLE POWER. OTHER APPLICATIONS COULD VOID WARRANTY. USER ACCEPTS RESPONSIBILITY FOR INJURIES AND/OR DAMAGE RESULTING FROM OTHER APPLICATIONS.**

**This Manual contains information to ensure your safety and to prevent any equipment problems. Various terms such as 'WARNING', 'CAUTION', 'DANGER', 'IMPORTANT', and the SYMBOL are all used to signify information that is essential for the operator of this equipment to understand and to practice!**



Travelers Rest, S.C. 29690  
(800) 845-4141

**MODEL TG 6500ES  
GAS POWERED  
ELECTRIC GENERATOR**

Model	TG 6500
Voltage	120/240
Frequency	60Hz
Continuous Watts	6000
Surge Watts	6500

**DESCRIPTION**

**TITAN MODEL TG 6500ES** is a gas engine driven, revolving field, alternating current (AC) generator designed to supply electrical power for compatible electrical tools, motors, appliances, and lighting (see wattage reference guide on page 8 ).

The Model PLG 6500ES operates at 120 volt and/or 240 volt, single phase, 60 Hz and will operate devices that require up to 6000watts continuous, 6500ES surge watts.

Figure #1 - Grounding Lug Block



**CONNECTING LOADS**

Add up the Watts of all devices you connect to the TITAN Generator at one time. Do not exceed 6000 Watts on TITAN Generator Model TG 6500ES (see wattage reference guide).

The rated Watts of most electrical devices can be found on its nameplate. The rated Watts of lights can be taken from the light bulbs. In cases where only Volts and Amps are shown on the nameplate, simply multiply Volts by the Amps to get Watts (Volts X Amps = Watts).

Some electric motors require about **three** times the rated Watts of power for start-up. This surge of power is required for only a few seconds. Be sure to allow for this high starting wattage when selecting electrical devices to connect to the generator.

First, figure the watts needed to start the largest motor. Add to that figure the running watts of all other connected loads.

Please see the Wattage Reference Guide. It provides an **estimated** approximation of running watts, to help determine which devices to select to connect to the generator.

**CAUTION!** Do not tamper with engine governed speed. The TITAN Generator supplies correct rated frequency and voltage when running at the proper governed speed. Incorrect frequency and/or voltage could damage connected electrical devices.

**GROUNDING THE GENERATOR**

It is required by The National Electrical Code to have the frame and all external conductive parts of the generator connected to an earth ground. Proper grounding also satisfies most local electrical codes.

Connect a No. 12 AWG standard copper wire to the Grounding Lug Block (See Figure 1). The grounding lug can be found on the front of the control panel. Connect the other end of the wire to an earth driven copper or brass grounding rod (electrode).

**CAUTION!** Do not connect ground to a preexisting ground rod, water pipe, or building frame.

Consult with a licensed electrician in your area because local codes vary. Properly grounding the generator helps prevent electrical shock if a ground fault condition exists in the generator or in connected electrical devices. This will also help to dissipate static electricity resulting from ungrounded devices.

# Z SAFETY Z

This generator was designed for specific applications. DO NOT attempt to modify the unit in any way or use it for any application that it was not designed to do. Ask the dealer or contact the factory if you have any questions concerning the generator's application.

Warnings and cautions in this manual and on decals and tags on the unit are not all inclusive. It would be impossible to anticipate every circumstance that might involve a hazard. Handling, operating, or servicing this unit by any procedure not recommended by the manufacturer may render this equipment unsafe and may pose a threat to you or to others.

- Z The generator produces a very powerful voltage that can cause extremely dangerous electrical shock. Avoid contact with bare wires, terminals, etc. never permit an unqualified person to operate or service the generator.
- Z Never handle any kind of electrical cord or device while standing in water, while barefoot or with wet hands or when feet are wet. Dangerous electrical shock could result.
- Z The National Electric Code requires that the frame and external conductive parts be properly connected to an approved earth ground. Local electrical codes may vary. Check with an electrician for local grounding requirements.
- Z Use a ground fault circuit interrupter in any damp or highly conductive area such as metal decking or steel work.
- Z Do not use worn, bare, frayed or otherwise damaged electrical cords or wiring with the generator. A defective cord may result in electrical shock or may cause damage to equipment.
- Z Do not expose unit to excessive moisture, dirt or corrosive vapors. Unit must be operated on a level surface.
- Z Do not overfill the fuel tank. Always allow room for fuel expansion. Fuel could overflow and cause fire or explosion if tank is overfilled. Allow for a 20 minute cool down before refueling. Never refuel tank while engine is running.

**Caution: Customer takes full responsibility for use**

- Z Only operate this unit outside with adequate ventilation. This generator's exhaust produces carbon monoxide gas that can cause unconsciousness or even death.
- Z Never store a generator with fuel in the tank where fuel vapors could be ignited by a flame, spark, or pilot light from an appliance such as a furnace, water heater, or clothes dryer.
- Z Always allow a minimum of 2 feet of clearance on all sides for ventilation while unit is operating. Allow 2 feet of clearance from all combustibles.
- Z Generator must always be stopped or started with all loads unconnected. Start the engine and let it stabilize before connecting any loads. Disconnect all loads before shutting down the generator.
- Z Never insert any object through the cooling slots of the engine. You could damage the unit or cause injury.
- Z NEVER OPERATE THE GENERATOR:
  - In rain
  - In an enclosed compartment
  - If connected devices overheat
  - If electrical output is lost
  - If engine or generator sparks
  - If flame or smoke is observed
  - If unit vibrates excessively

**CAUTION! The engine exhaust contains chemicals known to the State of California to cause cancer, birth defects, or other reproductive harm.**

**CAUTION! If it is your first time starting the generator, allow it to run for 30 minutes before connecting electrical loads. This is for wet seating purposes**

# OPERATION OF THE GENERATOR

## Starting the engine

- Z 1. Check oil and fuel levels
- 2. Turn fuel valve to the “ON” position
- 3. Put choke lever in the “ON” position
- 4. Turn the Ignition Switch on the control panel to the On Position (Electric start)
- 5. Pull the Recoil Starter Briskly until engine is running.(Manual start)
- 5. Return choke lever to the “OFF” position

## Connecting electrical loads

- Z Let engine stabilize and warm up for at least 3 minutes.
- Z Make sure devices to be connected are in good working order and in the “OFF” position before connecting to the generator.
- Z Make sure to plug in desired devices into the correct receptacle.
- Z DO NOT connect 240 Volt loads to the 120 Volt duplex receptacles.
- Z DO NOT connect 3 phase loads to the generator.
- Z DO NOT connect 50 Hz loads to the generator. This is a 60Hz System.
- Z DO NOT overload the generator. Add up the rated Watts of all loads to be connected. This total should not exceed the total watts of the generator.

## Stopping the engine

- Z Turn off all electrical devices connected to the generator.
- Z **WARNING:**  
**DO NOT start or stop generator with electrical devices plugged in.**
- Z Allow the generator engine to run at a ‘No Load’ condition for several minutes to stabilize internal engine temperature before stopping
- Z Turn the Ignition switch to the “OFF” position. on the control panel.
- Z Turn fuel valve to the “OFF” position

## Generator maintenance

(see maintenance table for list page 8).

- Z Keep the generator clean and dry. Use a damp cloth to clean exterior surfaces. Remove caked on dirt with a soft brush.
- Z Never spray with water. Water can contaminate the engine fuel system and cause serious problems in the generator.
- Z Damage may occur if engine or carburetor cleaning products are used.

## Storage

- Z **IMPORTANT:**  
  
(See Page 11)

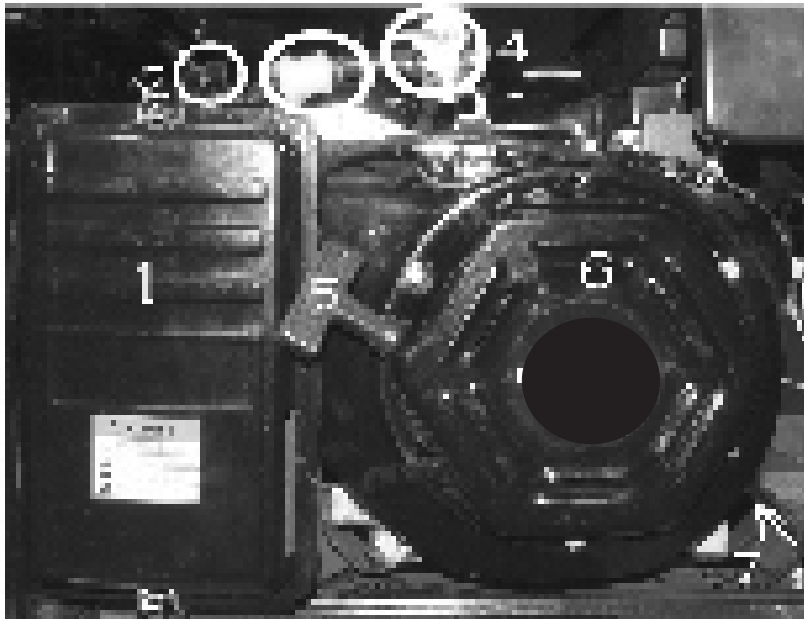

1. AIR FILTER
2. CHOKE LEVER
3. FUEL LINE WITH FILTER
4. FUEL SHUT OFF VALVE
5. PULL START
6. RECOIL ASSEMBLY
7. OIL DRAIN PLUG

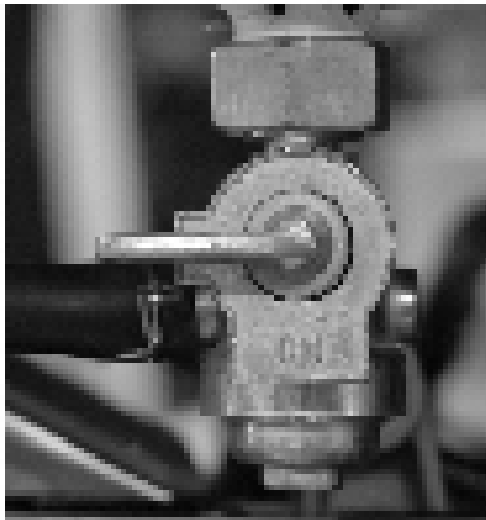

### FUEL SHUT OFF VALVE

TURN FUEL VALVE TO THE OFF POSITION WHEN UNIT IS NOT IN USE.

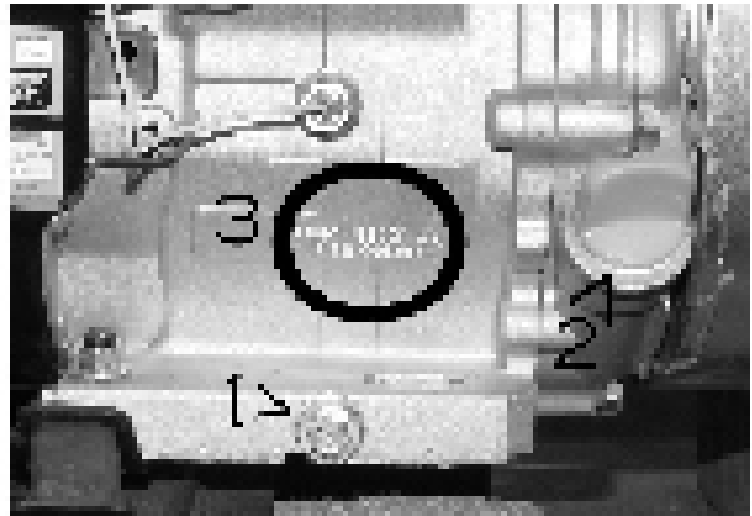

### OIL DRAIN AND FILL

1. OIL DRAIN PLUG
2. OIL FILL
3. ENGINE SERIAL NUMBER

OIL DRAIN AND FILL MAY BE PERFORMED ON RIGHT OR LEFT SIDE OF ENGINE.

OIL CAPACITY 28.25 OZ.

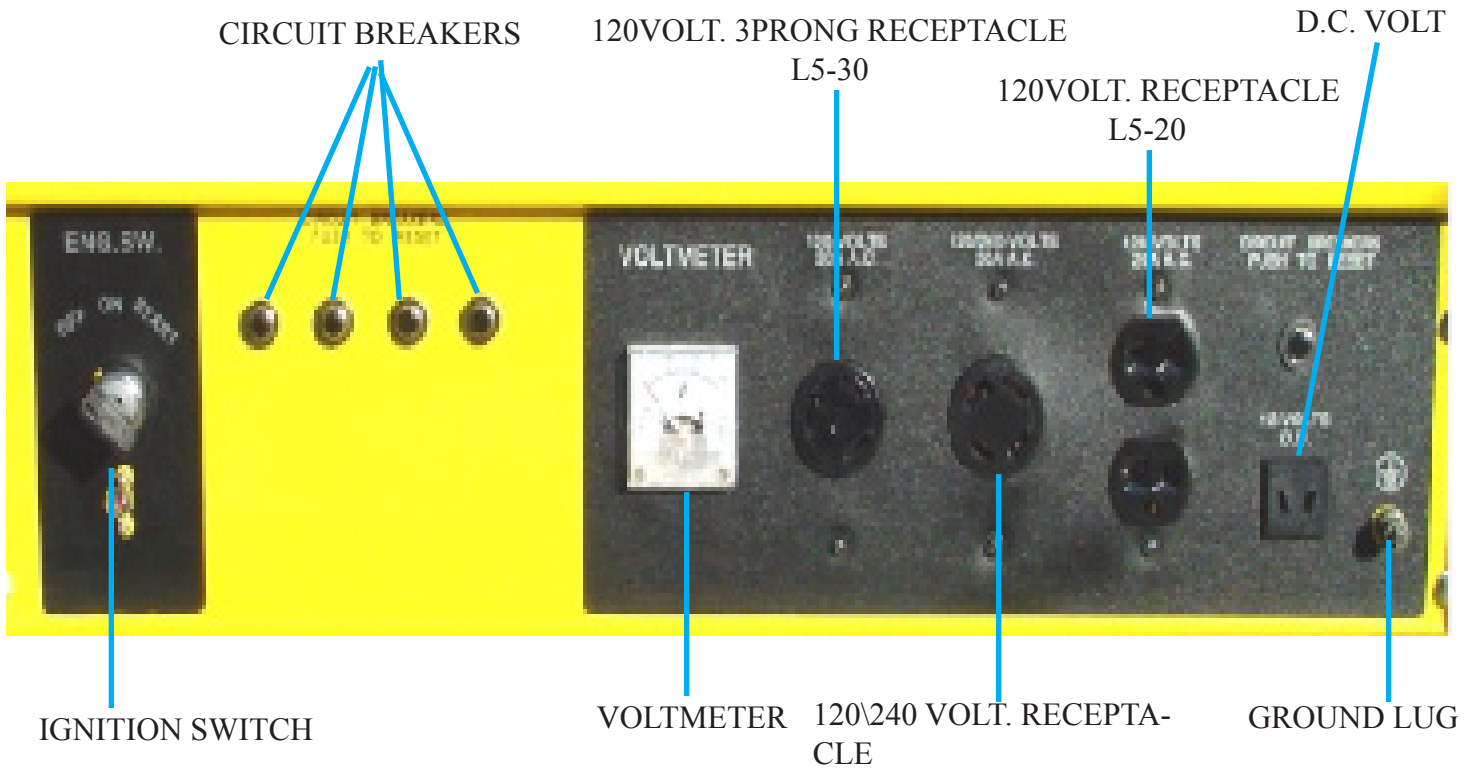

# TITAN

P.O.Box 791, Travelers Rest, S.C. 29690

### Wattage Reference Guide

Device	Running Watts	Device	Running Watts
*Air Conditioner (12,000 BTU)	1700	Impact Wrench	500
Battery Charger (20 Amp)	500	*Jet Pump	800
Belt Sander (3")	1000	Lawn Mower	1200
Chain Saw	1200	Light Bulb	100
Circular Saw (6-1/2")	800 to 1000	Microwave Oven	700
Coffee Maker	1000	*Milk Cooler	1100
Compressor (1 HP)	2000	Oil Burner on Furnace	300
Compressor (3/4 HP)	1800	Oil Fired Space Heater (140,000 BTU)	400
Compressor (1/2 HP)	1400	Oil Fired Space Heater (85,000 BTU)	225
Curling Iron	700	Oil Fired Space Heater (30,000 BTU)	150
*Freezer	500	*Airless Paint Sprayer (1/3 HP)	600
Disc Sander (9")	1200	Handheld Airless Paint Sprayer	150
Edge Trimmer	500	Electric Radio	50 to 200
Nail Gun	1200	Refrigerator	600
Electric Range (one element)	1500	Slow Cooker	200
Electric Skillet	1250	*Submersible Pump (1-1/2 HP)	2800
*Furnace Fan (1/3 HP)	1200	*Submersible Pump (1 HP)	2000
Hair Dryer	1200	*Submersible Pump (1/2 HP)	1500
Hand Drill (1")	1100	Sump Pump	600
Hand Drill (1/2")	750 to 1000	*Table Saw (10")	1750 to
Hand Drill (3/8")	500	2000	
Hand Drill (1/4")	250	Television	200 to 500

**\*Allow 3 times the listed Watts for starting these devices**  
**These wattages shown are approximate and may vary with each specific device**

### Maintenance Guide

	DAILY	EVERY MONTH/ 30 HRS	EVERY 3 MONTHS/ 100 HRS	EVERY 6 MONTHS/ 500 HRS
<b>Check/Refill Fuel</b>	X			
<b>Drain fuel from tank</b>			X	
<b>Check/Refill Oil</b>	X			
<b>Check for oil leakage</b>	X			
<b>Change oil</b>			* X	
<b>Replace air filter</b>			X*	
<b>Clean/Replace fuel filter</b>				X

\*First oil change should be after the first (5) hours of use. After initial break-in period change oil every 30 hours.

X\* Air filter may need to be replaced frequently, due to adverse conditions. Check filter frequently.

## Engine Oil

### NOTICE

Engine oil is a major factor affecting engine performance and service life. Non detergent and 2-stroke engine oils will damage the engine and are not recommended.

Check the oil level **BEFORE EACH USE** with the generator on a level surface and the engine stopped.

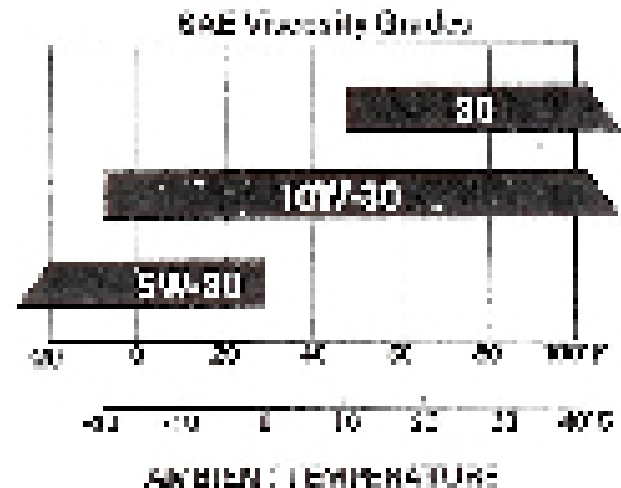

SAE 10W-30 is recommended for general, all-temperature use. Other viscosities shown in the chart may be used when the average temperature in your area is within the indicated range.

1. Remove the oil filler cap and wipe the dipstick clean.
2. Check the oil level by inserting the dipstick into the filler neck without screwing it in.
3. If the level is low, fill to the top of the oil filler neck with the recommended oil.

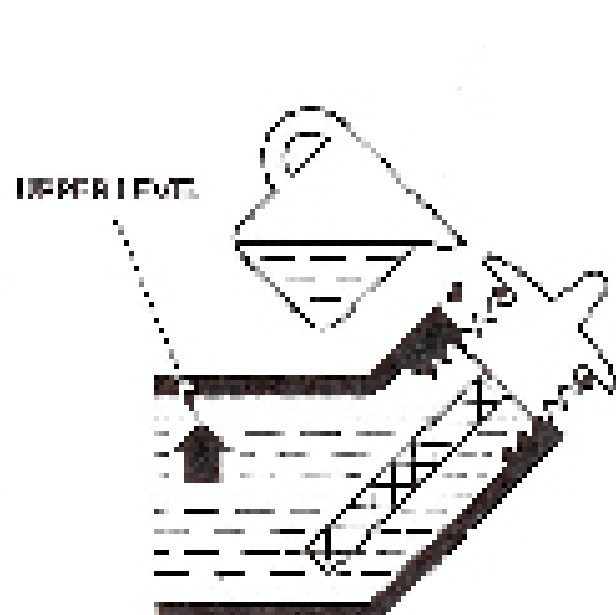
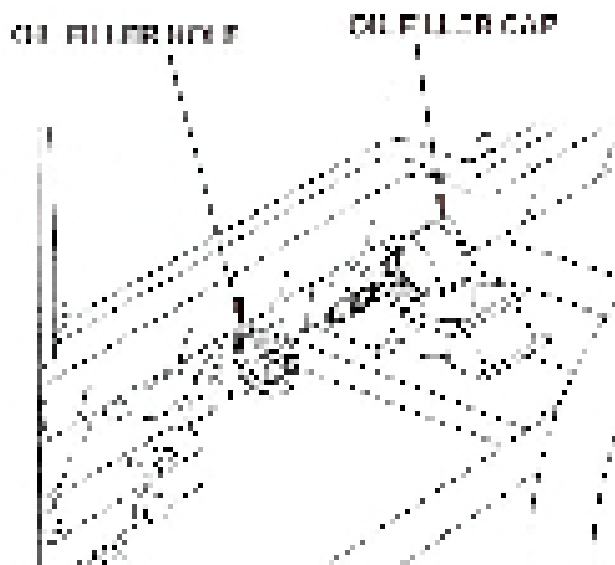

---

## Engine Oil Change

Drain the oil while the engine is warm to assure rapid and complete draining.

1. Remove the drain plug and sealing washer, remove the oil filler cap, and drain the oil.
2. Reinstall the drain plug and sealing washer. Tighten the plug securely.
3. Refill with the recommended oil (see page 9 ) and check the oil level.

Oil capacity:

42oz.

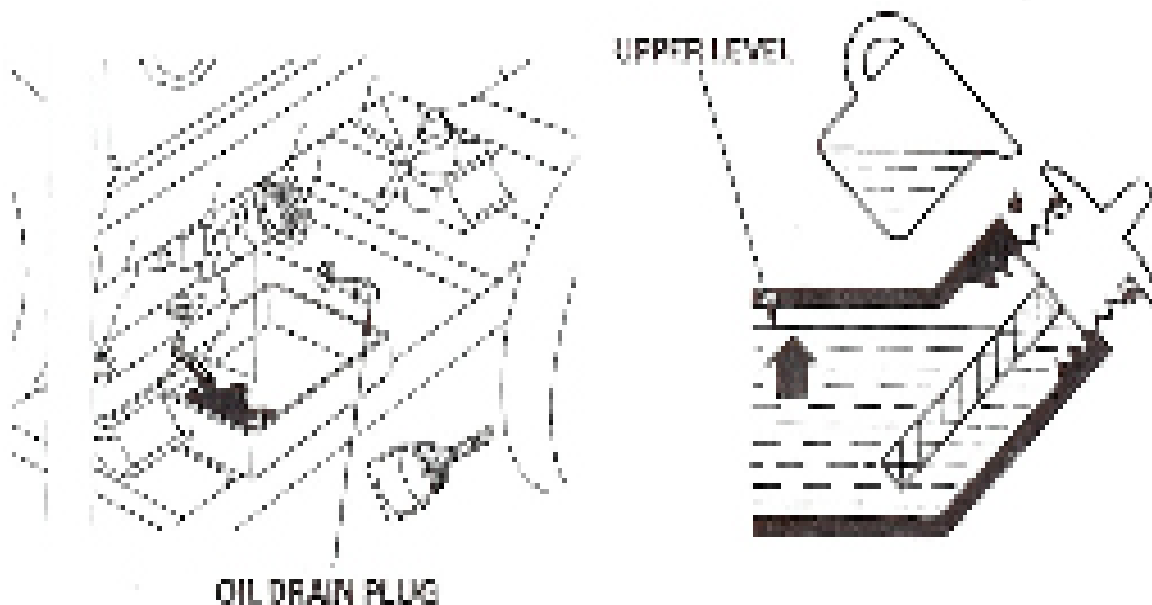

Wash your hands with soap and water after handling used oil.

Please dispose of used motor oil in a manner that is compatible with the environment. We suggest you take it in a sealed container to your local service station or recycling center for reclamation. Do not throw it in the trash, pour it on the ground, or down a drain.

## Storage

Before storing the unit for an extended period:

1. Be sure the storage area is free of excessive humidity and dust.
2. Service according to the table below:

<b>STORAGE TIME</b>	<b>RECOMMENDED SERVICE PROCEDURE TO PREVENT HARD STARTING</b>
Less than 1 month	No preparation required
1 to 2 months	Fill with fresh gasoline and add gasoline conditioner <sup>*</sup> .
2 months to 1 year	Fill with fresh gasoline and add gasoline conditioner <sup>*</sup> . Drain the carburetor float bowl. Drain the fuel sediment cup.
1 year or more	Fill with fresh gasoline and add gasoline conditioner <sup>*</sup> . Drain the carburetor float bowl. Drain the fuel sediment cup. Remove the spark plug. Put a tablespoon of engine oil into the cylinder. Turn the engine slowly with the pull rope to distribute the oil. Reinstall the spark plug. Change the engine oil. After removal from storage, drain the stored gasoline into a suitable container, and fill with fresh gasoline before starting.

<sup>\*</sup>Use gasoline conditioners that are formulated to extend storage life.

---

## Spark Plug Service

In order to service the spark plug, you will need a spark plug wrench (commercially available).

**Recommended spark plugs: BPR5FS (NGK)**

To ensure proper engine operation, the spark plug must be properly gapped and free of deposits.

If the engine has been running, the muffler will be very hot. Be careful not to touch the muffler.

1. Remove the spark plug cap.
2. Clean any dirt from around the spark plug base.
3. Use a spark plug wrench to remove the spark plug.



4. Visually inspect the spark plug. Discard it if the insulator is cracked, chipped or fouled.
5. Measure the plug gap with a feeler gauge. Correct as necessary by carefully bending the side electrode. The gap should be:  
0.028 – 0.031 in (0.70 – 0.80 mm)

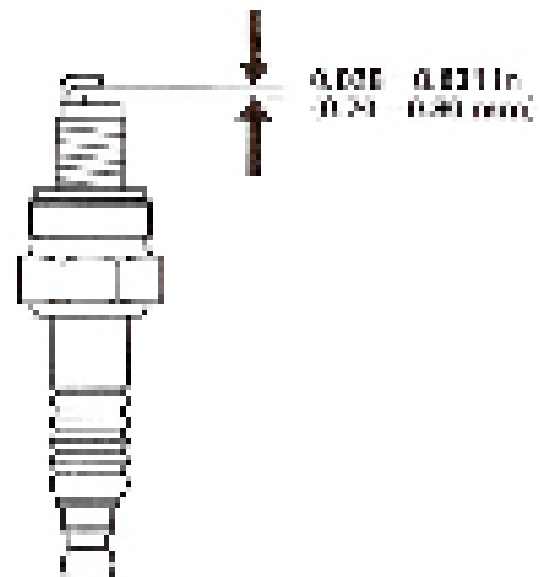

# TROUBLESHOOTING

Problem	Cause	Solution
Engine is running but no power output is available.	<ol style="list-style-type: none"> <li>1. Circuit breaker is open.</li> <li>2. Poor connection or defective cord set.</li> <li>3. Connected device is bad.</li> <li>4. Fault in generator.</li> </ol>	<ol style="list-style-type: none"> <li>1. Reset the circuit breaker.</li> <li>2. Check &amp; repair.</li> <li>3. Connect another device that is in good condition.</li> <li>4. Contact service center.</li> </ol>
Engine runs good until loads are connected, then bogs down.	<ol style="list-style-type: none"> <li>1. Short circuit in a connected load.</li> <li>2. Overloaded generator.</li> <li>3. Engine speed is too slow.</li> <li>4. Short in generator circuit.</li> </ol>	<ol style="list-style-type: none"> <li>1. Disconnect shorted load.</li> <li>2. See 'Connecting Electrical Loads' section of manual.</li> <li>3. Contact service center.</li> <li>4. Contact service center.</li> </ol>
Engine will not start or engine starts but runs rough.	<ol style="list-style-type: none"> <li>1. On/Off Switch is turned 'OFF'.</li> <li>2. Battery is dead</li> <li>3. Dirty air cleaner.</li> <li>4. Not enough speed or force is used for recoil start.</li> <li>5. Water in fuel.</li> <li>6. Speed control is not set to "RUN".</li> <li>7. Low oil level.</li> <li>8. Engine has lost compression.</li> </ol>	<ol style="list-style-type: none"> <li>1. Turn On/Off Switch to 'ON'.</li> <li>2. Charge or replace it.</li> <li>3. Clean air filter</li> <li>4. Read and follow directions.</li> <li>5. Drain and refill tank.</li> <li>6. Move speed control to "RUN" position.</li> <li>7. Add oil to proper level.</li> <li>8. Contact service center.</li> </ol>
Engine shuts down during operation.	<ol style="list-style-type: none"> <li>1. Out of fuel.</li> <li>2. Fault in engine.</li> </ol>	<ol style="list-style-type: none"> <li>1. Fill fuel tank.</li> <li>2. Contact service center</li> </ol>
Engine lacks power	<ol style="list-style-type: none"> <li>1. Load is too high.</li> <li>2. Dirty air filter.</li> <li>3. Engine needs to be serviced.</li> </ol>	<ol style="list-style-type: none"> <li>1. See 'Connecting Electrical Loads' section of manual.</li> <li>2. Replace the air filter.</li> <li>3. Contact service center.</li> </ol>

# TITAN

P.O. Box 791  
Travelers Rest, S.C. 29690  
(800) 845-4141

## Model TG 6500ES



### Specifications:

---

- |   |  |   |                                  |
|---|--|---|----------------------------------|
| Z | <b>Output 6000watts Continuous<br/>6500watts Surge</b> | Z | <b>Rpm 3720</b>                  |
| Z | <b>1- L5-20 Receptacle</b>                             | Z | <b>Brush type Generator Head</b> |
| Z | <b>1- L14-30 Receptacle</b>                            | Z | <b>AVR Voltage Regulator</b>     |
| Z | <b>1- L5-30 Receptacle</b>                             | Z | <b>Copper Windings</b>           |
| Z | <b>Circuit Breaker Protection</b>                      | Z | <b>Single Phase 60Hz.</b>        |
| Z | <b>74 Decibel's @ 10'</b>                              | Z | <b>Low Oil Shut Down</b>         |
| Z | <b>Manual/Electric Start</b>                           | Z | <b>Oil Capacity- 42oz.</b>       |
| Z | <b>13hp Gasoline Engine</b>                            | Z | <b>Size: L-27" W-20" H-22"</b>   |
| Z | <b>Steel Sleeve Cylinder</b>                           | Z | <b>Net. Weight 212 LBS.</b>      |
| Z | <b>5 Gallon Fuel Tank</b>                              | Z | <b>One Year Warranty</b>         |
| Z | <b>Approx. Run Time 10hrs<br/>@50% Load</b>            |   |                                  |

# MODEL TG 6500ES Generator



**MODEL TG 6500ES**

# TITAN

**P.O. Box 791 • Travelers Rest, SC 29690 •  
(800) 845-4141**